

Quicklub Oil Pump Model PPO

Table contents

Contents	Page
Quicklub Oil pump model PPO	2
Technical Data	2
Commissioning of the system	3
Pump and main lines	3
Typical outlet combination	3
PPO with 1,8-litre reservoir (Side view)	4
PPO with 0,6-litre reservoir (Side view)	5
PPO with 1,8-litre reservoir (Front view)	6
Spare parts list	7
Troubleshooting	8

Quicklub Oil pump model PPO

Model	Part -No.
PPO 6	604-27229-1
PPO18	604-27223-1

Filling of reservoir

The reservoir is filled through the filler cap at the top of the reservoir. The strainer **must** be in place when filling the reservoir. Strainer should be removed and cleaned periodically.

Technical Data

Pump pressure ratio 40:1
Air pressure min. 4 bar max. 10 bar
Max. operating pressure 300 bar
Lubricant output per outlet and stroke 2,6 cm ³
Air inlet G1/8"
Lube outlet Ø 6 mm
Reservoir capacities	PPO 18 1.8 litre PPO6 0.6 litre

Description

The QUICKLUB pump model PPO is used in a progressive type centralized lubrication system. It is a pneumatically operated, single-stroke pump requiring a 3/2-way air valve for activating the air cylinder. It has a clear reservoir for visual inspection of oil level.

Important: Do not use any solvents for cleaning the clear reservoir!

Operation

When the solenoid is energized, compressed air enters the air cylinder bottom and moves the piston upward. As the piston moves upward, the ball seat of the suction valve prevents the lubricant from returning to the lubricant reservoir. Lubricant is therefore dispensed from the outlet of the pump.

When the solenoid is de-energized, the compressed air leaves the air cylinder. The air piston spring moved the air piston downward. The ball of the suction valve unseats allowing lubricant from reservoir to refill the discharge cavity in the pump body for the next lubrication cycle.

Important: The pump must be installed in vertical position.

Commissioning of the system

Pump and main lines

After the reservoir has been filled with recommended lubricant, loosen vent screw counter nut and open vent screw approximately one turn (DO NOT REMOVE).

Also, loosen main line fittings. Operate pump until lubricant flows from vent screw, then tighten vent screw and counter nut. Continue to operate pump until lubricant flows loosened main lines, then tighten metering device inlet fitting. Repeat procedure until all main lines are filled.

Typical outlet combination

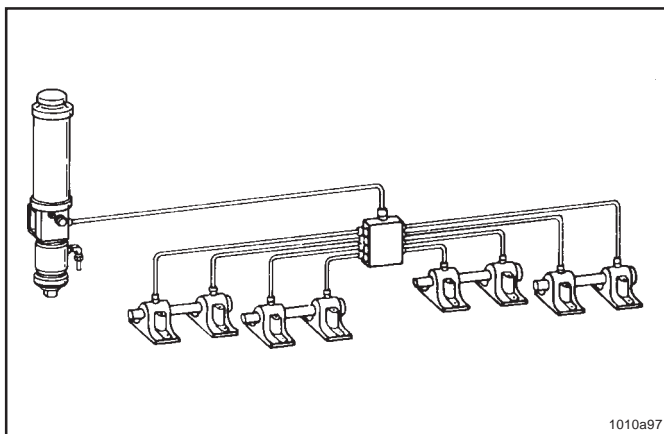

Lubrication system with main metering device

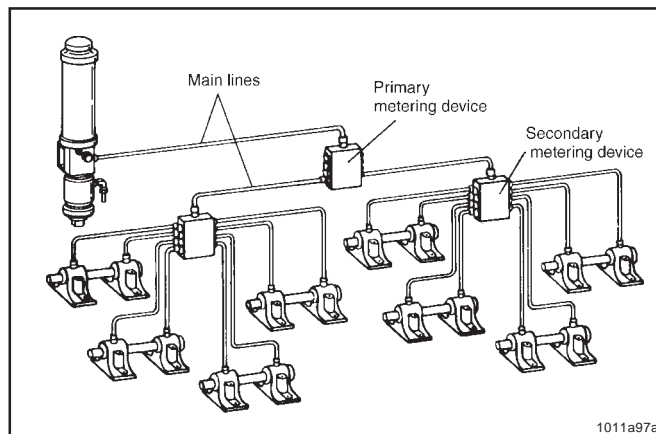

Lubrication system with main metering device and secondary metering devices

PPO with 1,8-litre reservoir (Side view)

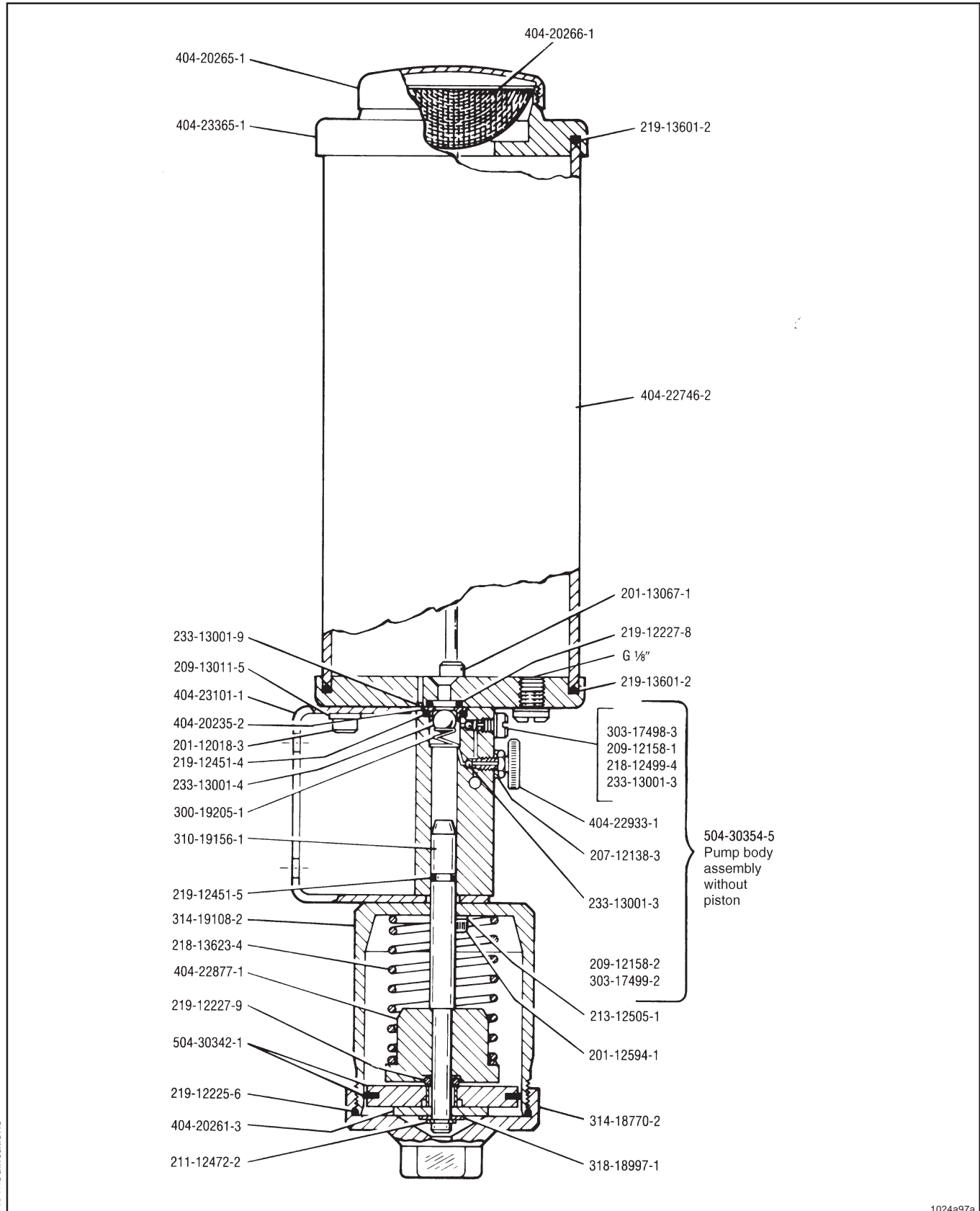

1024a97a

Subject to modifications

PPO with 0,6-litre reservoir (Side view)

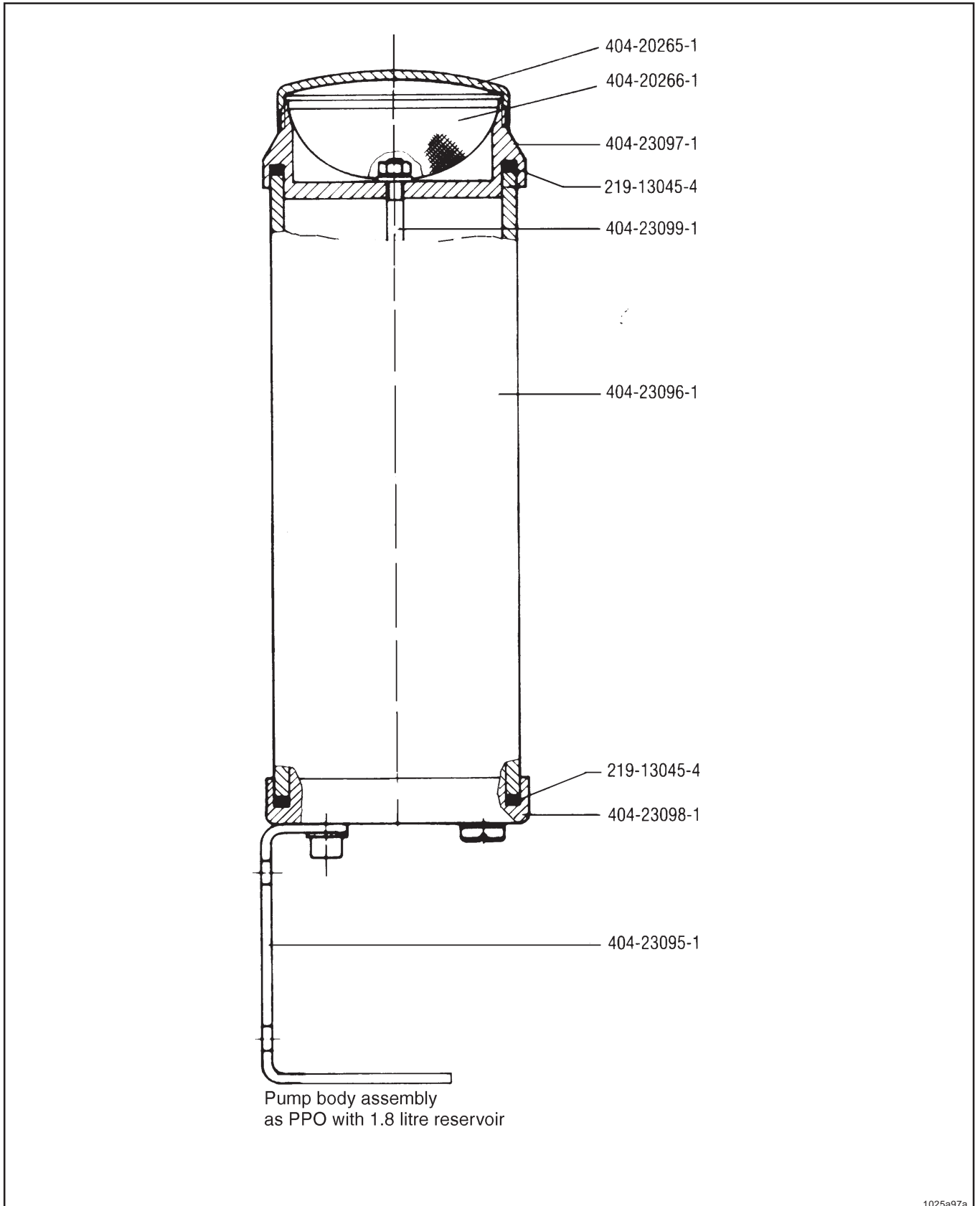

Subject to modifications

1025a97a

PPO with 1,8-litre reservoir (Front view)

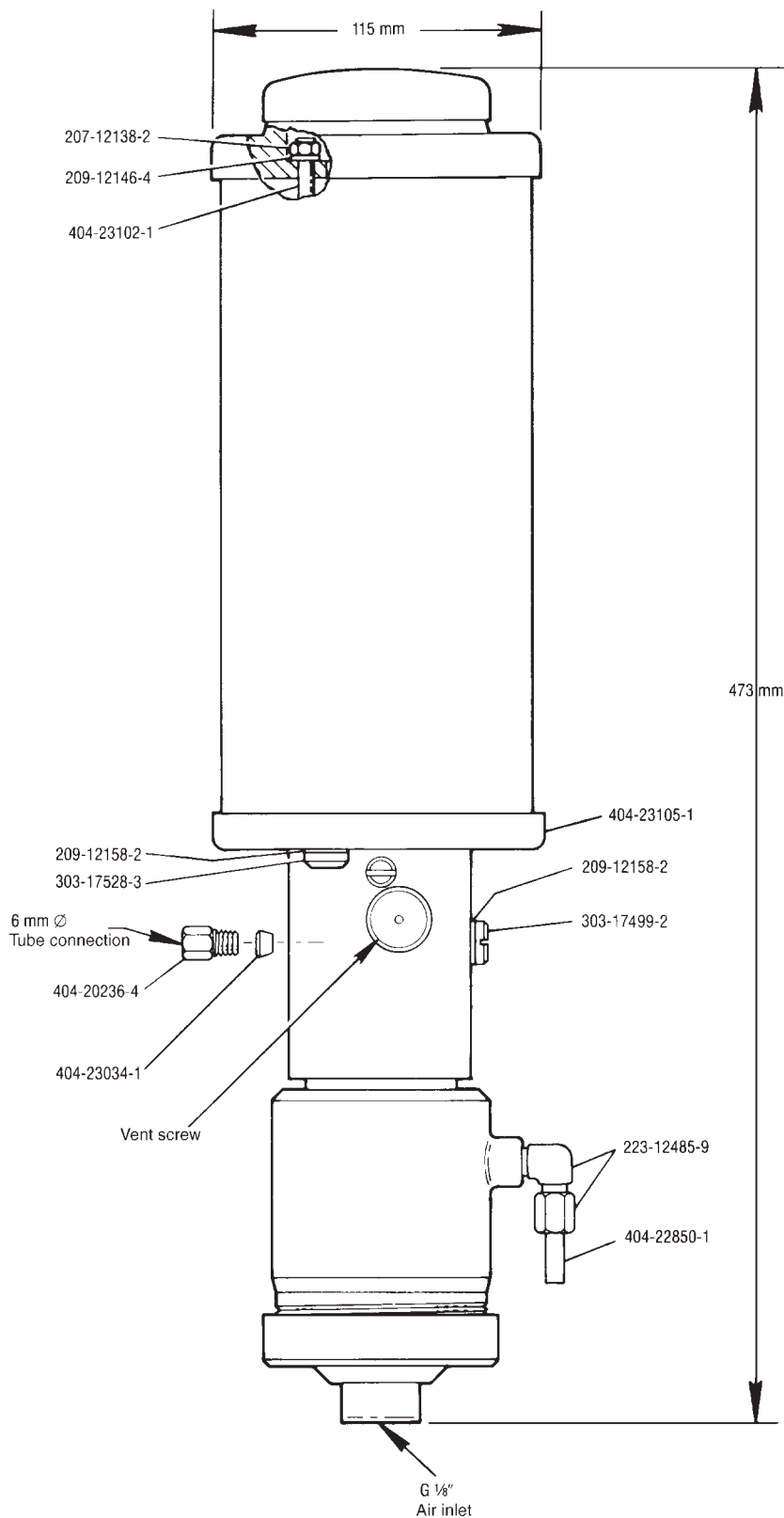

Subject to modifications

1026a97a

Spare parts list

PPO with 1,8-litre reservoir

	Description	Qty.	Part No.
1	Hex. socket head screw	2	201-12018-3
2	Hex. socket head screw	2	201-12594-1
3	Hex. socket head screw	2	201-13067-1
4	Hex. nut	2	207-12138-2
6	Hex. nut	1	207-12138-3
7	Washer	2	209-12146-4
8	Gasket	1	209-12158-1
9	Gasket	2	209-12158-2
10	Washer	2	209-13011-5
11	Retaining ring	1	211-12472-2
12	Spring washer	2	213-12505-1
13	Compression spring	1	218-12499-4
14	Compression spring	1	218-13623-4
15	O-ring	1	219-12222-1
16	O-ring	1	219-12225-6
17	O-ring	1	219-12227-8
18	O-ring	1	219-12227-9
19	O-ring	1	219-12451-4
20	O-ring	1	219-12451-5
21	O-ring	2	219-13601-2
22	WE6-LLR1/8 KC	1	223-12485-9
23	Steel ball	2	233-13001-3
24	Steel ball	1	233-13001-7
25	Steel ball	2	233-13001-9
26	Compression spring	1	300-19205-1
27	Closure plug	1	303-17498-3
28	Closure plug	1	303-17499-2
29	Closure plug	1	303-17528-3
30	Piston	1	310-19156-1
31	Bottom	1	314-18770-2
32	Cylinder	1	314-19108-2
33	Washer	1	318-18997-1
34	Ball seat	1	404-20235-2
35	Compression nut	1	404-20236-4
36	Washer	1	404-20261-3
37	Cover	1	404-20265-1
38	Strainer	1	404-20266-1
39	Reservoir tube	1	404-22746-2
40	Vent tube	1	404-22850-1
41	Stop	1	404-22877-1
42	Vent screw	1	404-22933-1
43	Clamping ring	1	404-230437-1
44	Bracket	1	404-23101-1
45	Securing stud	2	404-23102-1
46	Bottom	1	404-23105-1
47	Adapter	1	504-30365-1
48	Pneumatic piston dia. 63	1	504-30342-1
49	Pump body assembly complete without piston	1	504-30354-5

PPO with 0,6-litre reservoir

	Description	Qty.	Part No.
1	O-ring	2	219-13045-4
2	Bracket	1	404-23095-1
3	Reservoir tube	1	404-23096-1
4	Adapter	1	404-23097-1
5	Bottom	1	404-23098-1
6	Securing stud	1	404-23099-1

Subject to modifications

Troubleshooting

<ul style="list-style-type: none"> • Fault: Pump actuates without delivering lubricant 	
<ul style="list-style-type: none"> • Cause 	<ul style="list-style-type: none"> • Remedy
<ul style="list-style-type: none"> • Lubricant reservoir empty. 	<ul style="list-style-type: none"> • Check lubricant level in reservoir and fill, if necessary.
<ul style="list-style-type: none"> • Fault: Pump does not actuate with air pressure to cylinder 	
<ul style="list-style-type: none"> • Cause 	<ul style="list-style-type: none"> • Remedy
<ul style="list-style-type: none"> • 3/2-way solenoid defective. 	<ul style="list-style-type: none"> • Check solenoid valve, repair or replace, if necessary.
<ul style="list-style-type: none"> • Fault: Although compressed air available at air cylinder, piston does not complete its stroke (indicator pin does not move) 	
<ul style="list-style-type: none"> • Cause 	<ul style="list-style-type: none"> • Remedy
<ul style="list-style-type: none"> • Blockage in delivery line. 	<ul style="list-style-type: none"> • Pressurize pump. Loosen fitting on pump body and check for lubricant delivery. Then loosen fittings at metering devices or lubricant points until lubricant emerges from outlets and pump actuates. This will indicate in which line the blockage has occurred. Clear blockage. Tighten all loose fittings.
<ul style="list-style-type: none"> • Fault: Air escapes from cylinder vent tube. Air cylinder is activated and piston is at top of stroke 	
<ul style="list-style-type: none"> • Cause 	<ul style="list-style-type: none"> • Remedy
<ul style="list-style-type: none"> • O-ring 219-13043-6 or pneumatic piston 504-30342-2 with gasket worn or damaged. 	<ul style="list-style-type: none"> • Disconnect air supply. Unscrew air cylinder bottom 314-19241-1. Remove piston and disassembly all parts. Replace O-ring 219-12451-5, O-Ring 219-13043-6, pneumatic piston with gasket 504-30342-1 and retaining ring 211-12472-2. Reassemble piston and lubricate lightly with oil. Loosen vent screw counter nut and open vent screw approximately one turn (DO NOT REMOVE) and install pneumatic piston. Replace O-ring 219-12225-6 and reassemble air cylinder bottom. Reconnect air supply. Operate pump until lubricant flows from vent screw, then tighten vent screw and counter nut.
<ul style="list-style-type: none"> • Fault: Lubricant discharged at vent tube 	
<ul style="list-style-type: none"> • Cause 	<ul style="list-style-type: none"> • Remedy
<ul style="list-style-type: none"> • O-ring 219-12451-5 is worn or damaged. 	<ul style="list-style-type: none"> • Disconnect air supply. Unscrew bottom 314-18770-2. Remove piston and replace O-ring 219-12451-5 Lubricate piston lightly with oil. Loosen vent screw counter nut and open vent screw approximately one turn (DO NOT REMOVE) and install piston. Replace O-ring 219-12225-6 and reassemble air cylinder bottom. Reconnect air supply. Operate pump until lubricant flows from vent screw, then tighten vent screw and counter nut. Important: Before tightening, center air cylinder on bore hole of pump body.

Subject to modifications

<ul style="list-style-type: none"> • Fault: Lubricant leaking between reservoir and reservoir base 	
<ul style="list-style-type: none"> • Cause 	<ul style="list-style-type: none"> • Remedy
<ul style="list-style-type: none"> • O-ring 219-13601-2 damaged. 	<ul style="list-style-type: none"> • With reservoir empty, unscrew two nuts n 207-12138-2 and remove reservoir. Replace O-ring in reservoir base. Reassembly reservoir to base and secure with the two nuts.
<ul style="list-style-type: none"> • Fault: Lubricant leaking between pump body and reservoir base 	
<ul style="list-style-type: none"> • Cause 	<ul style="list-style-type: none"> • Remedy
<ul style="list-style-type: none"> • O-ring 219-12451-4, O-ring 219-12227-8 worn or damaged. 	
<ul style="list-style-type: none"> • Fault: Pump actuates without discharged lubricant 	
<ul style="list-style-type: none"> • Cause 	<ul style="list-style-type: none"> • Remedy
<ul style="list-style-type: none"> • Check valve ball 233-13001-7 and ball seat 404-20235-2 dirty, 	<ul style="list-style-type: none"> • With reservoir empty, unscrew two nuts 207-12138-2 and remove reservoir. Unscrew two hex. socket screws 201-13067-1 and two hex. screws 201-12018-3 and remove reservoir base. Disassemble suction valve and replace O-ring 219-12451-4. Clean and inspect check valve ball 233-13001-7 and ball seat 20235-2, replace if worn or damaged. Replace O-ring 219-12227-8 in reservoir base and assemble to pump body with two hex. socket screws 201-13067-1. Fasten mounting bracket to reservoir base with two hex. socket screws 201-12018-3 .